



Pure Sine Wave Inverter



GPSW-600
GPSW-1500

Owner's Manual





Table of Contents

Introduction	2
Specifications	3
Name and Main Function	5
Installation	9
Operation	11
Operating Limits	12
Troubleshooting	13
Maintenance	14
Disclaimer of Liability and Warranty	15
Configuring your GPSW-600/1500	18

1. Introduction

The Go Power! Sine Wave series models are used in a wide range of applications including remote homes, RVs, sailboats and powerboats. It will operate most televisions and VCRs, personal computers, small appliances and tools such as drills, sanders, grinders, mixers and blenders.

The inverter must have a greater power rating than the load it provides power to.

To get the most out of the power inverter, it must be installed and used properly. Please read the instructions in this manual before installing and using this model.



2. Specifications

2.1 1500 W Inverter

SPECIFICATIONS	GPSW-1500 (12V)	GPSW-1500 (24V)
Continuous Output Power	1500 W	
Surge Rating	2000 W	
Output Waveform	Pure Sine Wave <3% THD	
Output Voltage \pm 5%	115 VAC RMS	
Input Voltage	11 – 16.0 VDC	21.0-30.0
Efficiency	85-90%	
No Load Current Draw / Powersave	1.0 A / 0.1A	0.65 A / 0.05 A
Protection	Overload, Short Circuit, Reverse Polarity (Fuse), Over/Under Input Voltage, Over Temperature	
Low Battery Alarm \pm 2%	10.5 V	21 V
Low Battery Shut-Down \pm 2%	10.0 V	20.0 V
Operating Temperature Range	0 - 40°C / 32°F - 104°F	
Storage Temperature Range	-30°C - 70°C / -22°F - 158°F	
Cooling	Thermostatically Controlled Fan	
AC Receptacle	Dual GFCI	
Remote Port Option	Yes	
Dimensions (L x W x H) in mm	419 x 279 x 102	
Dimensions (L x W x H) in inches	16.3 x 10.9 x 4.1	
Weight	7.7 kg / 17 lbs	
Warranty	2 Years	
Inverter Install Kits	GP-DC-KIT3	GP-DC-KIT2
UPC	8-39085-00001-4	8-39085-00039-7



2.2 600 W Inverter

SPECIFICATIONS	GPSW-600 (12V)	GPSW-600 (24V)
Continuous Output Power	600 W	
Surge Rating	860 W	
Output Waveform	Pure Sine Wave <3% THD	
Output Voltage \pm 5%	115 VAC RMS	
Input Voltage	10.5– 15 VDC	21.0-30.0
Efficiency	85-92 %	
No Load Current Draw / Powersave	0.90 A	0.50 A
Protection	Overload, Short Circuit, Reverse Polarity (Fuse), Over/Under Input Voltage, Over Temperature	
Low Battery Alarm \pm 2%	10.7 V	21.4 V
Low Battery Shut-Down \pm 2%	10.3 V	20.6 V
Operating Temperature Range	0 - 40°C / 32°F - 104°F	
Storage Temperature Range	-30°C - 70°C / -22°F - 158°F	
Cooling	Thermostatically Controlled Fan	
AC Receptacle	Dual GFCI	
Remote Port Option	Yes	
Dimensions (L x W x H) in mm	295 x 180 x 72	
Dimensions (L x W x H) in inches	11.6 x 7.1 x 2.8	
Weight	2.7 kg / 5.9 lbs	
Warranty	2 Years	
Inverter Install Kits	GP-DC-KIT2	
UPC	8-39085-00007-6	8-39085-00018-2



3.0 Name and Main Function

3.1 Front View GPSW-1500

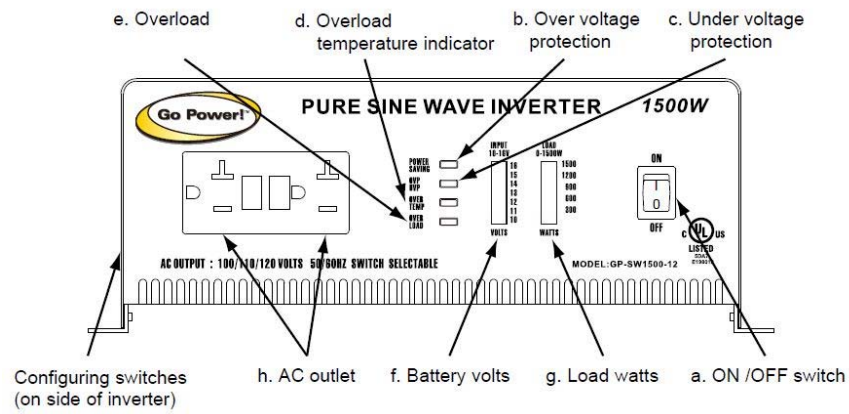

- a) ON / OFF switch:
Power ON/OFF switch, leave in the OFF position during installation.
- b) OVP: over voltage protection.
- c) UVP: under voltage protection
- d) OTP: over temperature protection.
- e) OLP: over load protection.
- f) BATT. VOLTS: display battery voltage.
- g) LOAD WATTS: display AC load watts.
- h) AC outlet: Ground Fault Protected (GFCI)



3.2 Rear View GPSW-1500

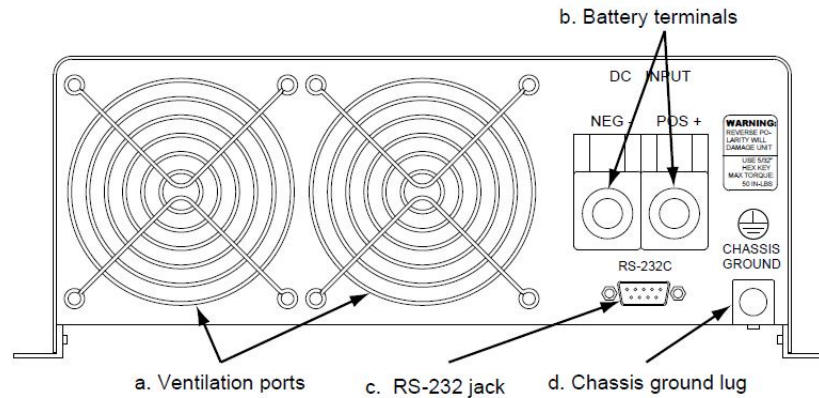

Warning! Operation of the inverter without a proper ground connection may result in an electrical safety hazard.

- a) Ventilation ports:
Do not obstruct, allow at least 1 inch for air flow.
- b) Battery terminals:
Connect to 12V / 24V battery or other 12V / 24V power source. [+] is positive [-] is negative. Reverse polarity connection will blow the internal fuse and may damage inverter permanently.
- c) RS-232C jack.
- d) Chassis ground or to vehicle chassis using # 8 AWG wire.



3.3 Front View GPSW-600

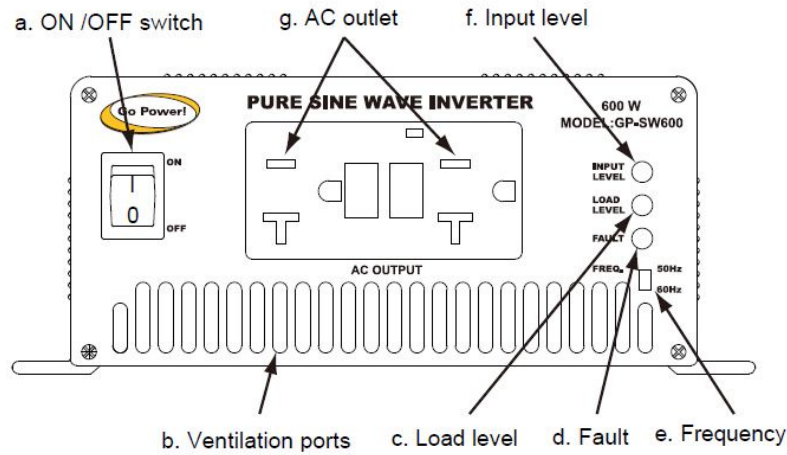

- a) ON / OFF switch:
Power ON/OFF switch, leave in the OFF position during installation.
- b) Ventilation ports:
Do not obstruct, allow at least 1 inch for air flow.
- c) Load Level:
Display AC load watts, green indicates normal operation and red indicates high load levels.
- d) Fault
- e) Frequency
- f) Input Level:
Display input voltage, green indicates normal operation and red indicates low battery level.
- g) AC outlet: Ground Fault Protected (GFCI)



3.4 Rear View GPSW-600

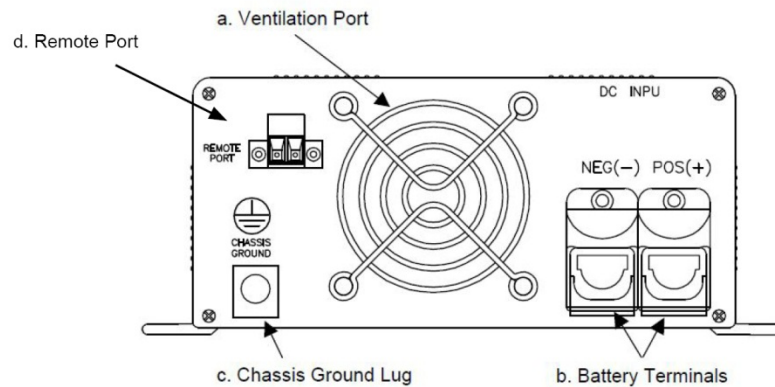

Warning! Operation of the inverter without a proper ground connection may result in an electrical safety hazard.

- a) Ventilation port:
Do not obstruct, allow at least 1 inch for air flow
- b) Battery terminals:
Connect to 12V battery or other 12V power source. [+] is positive [-] is negative. Reverse polarity connection will blow the internal fuse and may damage inverter permanently.
- c) Chassis ground or to vehicle chassis using # 8 AWG wire.
- d) Remote port allows customer to wire in any two wire remote switch to turn the inverter on and off. Eg. Toggle switch or light switch.



4.0 Installation

4.1 Where to install

The power inverter should be installed in a location that meets the following requirements:

- a) Dry - Do not allow water to drip or splash on the inverter.
- b) Cool - Ambient air temperature should be between 0°C and 40°C (the cooler the better).
- c) Ventilated - Allow at least two inches of clearance around the inverter for air flow. Ensure the ventilation openings on the rear and bottom of the unit are not obstructed.
- d) Safe - Do not install the inverter in the same compartment as batteries or in any compartment capable of igniting flammable liquids such as gasoline.
- e) Inverter should be located within 10 feet of the batteries.

4.2 Hook-up and testing

To hook-up please follow these guidelines:

1. Unpack and inspect your Go Power! Inverter, check to see that the power switch is in the OFF position. Set up your power output according to Section 10, Configuring your Sine Wave.
2. Insert DC inverter cables to the power input terminals on the rear panel of the power inverter. The red terminal is positive (+) and black terminal is negative (-). Connect the cables into the terminals and tighten the terminal screw to clamp the wires securely.
3. Connect the cable from the negative terminal of the inverter to the negative terminal of the battery. Make a secure connection.

Caution! Loose connections result in excessive voltage drop and may cause overheated wires and melted insulation.
4. Before proceeding further, carefully check that the cable you have just connected connects from the negative terminal of inverter to the negative output terminal of the power source.
5. Install inverter fuse in positive lead. Fuse should be located within 12" of battery. Ensure all connections are tight and secure.



6. Connect the cable from the positive terminal of inverter to the positive terminal of the battery. Make a secure connection.
7. Set the power switch to the ON position. Check the meters and indicators on the front panel of the inverter. The voltage indicator should indicate 12 to 14 volts depending on the voltage of the power source. If it does not, check your battery bank and the connections to the inverter.
8. Set the power inverter switch to the OFF position. The indicator lights may blink and the internal alarm may sound momentarily. This is normal. Plug the test load into the AC receptacle on the front panel of the inverter. Leave the test load switch OFF.
9. Set the power inverter switch to the ON position and turn the test load on; the inverter should supply power to the load. If you plan to measure the output voltage of the inverter, a true r.m.s. meter must be used for accurate readings.
10. Ensure battery interconnect cables are a minimum of #4 gauge wire and a maximum of 12" in length.

Caution! A reverse polarity connection will blow a fuse in the inverter and may permanently damage the inverter. Damage caused by reverse polarity connection is not covered by our warranty.

Warning!

You may observe a spark when you make this connection since current may flow to charge capacitors in the power inverter. Do not make this connection in the presence of flammable fumes, as explosion or fire may result.

4.3 Cables

DC to AC inverters require high amperage / low voltage DC power to low amperage / high voltage AC power. To operate properly connect inverter DC input terminals direct to battery with appropriate Go Power! Install kit.

4.4 Grounding

The power inverter has a lug on the rear panel [chassis ground]. This is to connect the chassis of the power inverter to the ground. The ground terminals in the AC outlets on the front panel of the inverter are also connected to the ground lug.

The chassis ground lug must be connected to a grounding point, which will vary depending on where the power inverter is installed. In a vehicle, connect the chassis ground to the chassis of the vehicle. In a boat, connect to the boat's grounding systems. In a fixed location, connect the chassis ground lug to earth.

The neutral (common) conductor of the power inverter AC output circuit is connected to the chassis ground. Therefore, when the chassis is connected to ground, the neutral conductor will also be grounded. This conforms to national



electrical code requirements that separately derived AC sources (such as inverters and generators) have their neutral tied to ground in the same way that the neutral conductor from the utility line is tied to ground at AC breaker panel.

Caution!

The negative DC input of the power inverter is connected to the chassis. Do not install the power inverter in a positive ground DC system. A positive ground DC system has the positive terminal of the battery connected to the chassis of the vehicle or to the grounding point.

Warning!

Do not operate the power inverter without connecting it to ground. Electrical shock hazard may result.

5.0 Operation

To operate the power inverter, turn it on using the ON/OFF switch on the front panel. The power inverter is now ready to deliver AC power to your loads. If you are operating several loads from the power inverter, turn them on separately after the inverter has been turned on. This will ensure that the power inverter does not have to deliver the starting-currents for all the loads at once.

5.1 Operating On/Off Switch

The ON/OFF switch turns the control circuit in the power inverter ON and OFF. It does not disconnect power from the power inverter. When the switch is in the OFF position, the power inverter draws no current from the battery. When the switch is in the ON position but with no load, the power inverter draws less than 1.65 A / normal, 0.07 A / saving mode (12 V version) from the battery.

5.2 Battery voltage indicator

The battery voltage bar graph on the SW1500 indicates the voltage at the input terminals of the power inverter. At low input current, this voltage is very close to the battery voltage. At high input current, this voltage will be lower than the battery voltage because of the voltage drop across the cable and connections. Ideally, the voltage should remain in the green area of the bar graph. If the voltage goes into the red area at the top and bottom of the graph, inverter may shut-down. The SW600 has a LED that changes colour from green to red as battery voltage decreases.

5.3 Load watt indicator

The AC load watt bar graph on the SW1500 indicates the power drawn from the power inverter. It will indicate watt by loads. For long-term operation, the watt should be in the green and orange area of the bar graph. The SW600 load level indicator should be green for long-term operation. Short-term operation is possible with the load indicator in the red area. If the load rises dangerous levels, the inverter will protect itself. The SW600 has a LED that goes from green to red at peak wattage.



5.4 Resetting Faults

Any of the inverters protection faults can be re-set by turning the inverter off for five seconds and then turning the inverter on again. The GPSW1500 can also re-set any of its protection faults using the optional remote on/off switch to turn the inverter off and then on again.

5.5 Over voltage indicator

The over voltage indicator indicates that the power inverter has shut itself down because its input voltage has been over 16.5 VDC for the 12 V and 32.0 VDC for the 24 V.

5.6 Under voltage indicator

The under voltage indicator indicates that the power inverter has shut itself down because its input voltage has been lower than 10.0 VDC for the 12 V and 20.0 VDC for the 24 V.

5.7 Over temp indicator

The over temp indicator indicates that the power inverter has shut itself down because it has become overheated. The power inverter may overheat because it has been operated at power levels above its rating, or because it has been installed in a location which does not allow it to dissipate heat properly. The power inverter will restart automatically once it has cooled off.

5.8 Overload indicator

The overload indicator indicates that the power inverter has shut itself down because its output circuit has been short circuited or drastically overloaded. Switch the ON/OFF switch to OFF, correct the fault condition, and then switch the ON/OFF switch back to ON.

5.9 Configuring switches

The configuring switches are used to configure the AC output of the inverter. In North America the output is typically configured to 115 VAC and 60 Hz.

5.10 Remote

If the remote is being used on the GPSW-1500, please refer to the GPSW remote manual for dip switch settings and operations. When using the GPSW-600-12 Remote Port option, simply connect the two terminals to turn the inverter on and disconnect them to turn the inverter off. For example you can wire to a toggle switch and use the toggle as the remote ON/OFF switch.

6. Operating limits

6.1 Power output

The SW1500 W inverter will operate most AC loads within its power rating.



When determining whether a microwave oven can be operated by the 1500 W inverter, remember that the power commonly advertised for microwave ovens is the cooking power (the power delivered to the food) not the power actually consumed by the microwave oven. The microwave oven will consume 40% to 100% more than its advertised cooking power. Check the rating sticker on the back of the oven to determine its actual power draw. The 1500 W inverter will operate a small microwave oven (0.2 to 3.0 cubic foot capacity) that draws up to 1800 watts. It will provide 10 to 15 minutes of cooking time, depending on battery capacity. Some induction motors used in refrigerators, freezers, pumps, and other motor-operated equipment require very high surge currents to start. The power inverter may not be able to start some of these motors even though their rated current draw is within the power inverter.

If the motor refuses to start, observe the battery voltage indicator while trying to start the motor. If the battery voltage indicator drops below 11 volts while the inverter is attempting to start the motor, this may be why the motor won't start. Make sure that the battery connections are good and the battery is charged, but if the voltage still drops below 11 volts, you may need to use a larger battery.

6.2 Input voltage:

The power inverter will operate from input voltage ranging 10-15V (GPSW-600W-12V ver.) and 10 V – 16 V (GPSW-1500-12V ver.) or 20 V-32 V (24 V ver.) If the voltage drops below 10.5 V (12 V ver.) or 21 V (24 V ver.), an audible low battery warning will sound and the voltage indicator will be in the lower red zone. The power inverter will shut down if the input voltage drops below 10 V (12 V ver.) or 20 V (24 V ver.). This protects your battery from being overly discharged.

The power inverter will also shut down if the input voltage exceeds 16 V (12 V ver.) or 32 V (24 V ver.). This protects the inverter against excessive input voltage. The voltage indicator will be in the upper red zone. Although the power inverter incorporates protection against over voltage, it may still be damaged if the input voltage is allowed to exceed 20 V (12 V ver.) or 40 V (24 V ver.).

7. Troubleshooting

7.1 Common problems

Television interference: Operation of the power inverter can interfere with television reception on some channels. If this situation occurs, the following steps may help to alleviate the problem.

- Make sure that the chassis ground lug on the back of the power inverter is solidly connected to the ground system of your vehicle, boat or home.
- Do not operate high power loads with the power inverter while watching television.



- Make sure that the antenna feeding your television provides an adequate ("snow free") signal and that you are using good quality cable between the antenna and the TV.
- Move the television as far away from the power inverter as possible.
- Keep the cables between the battery and the power inverter as short as possible and twist them together with about 2 to 3 twists per foot. This minimizes radiated interference from the cables.

7.2 Troubleshooting guide

Problem and Symptoms	Possible Cause	Solution
Low output voltage and current indicator in red zone.	Overload	Reduce load
No output voltage and voltage indicator in lower red zone.	Low input voltage	Recharge battery, check connections and cable.
No output voltage, no voltage indication.	Inverter switched off. No power to inverter	Turn inverter ON. Check wiring to inverter.
	Internal fuse open	Have qualified service technician check and replace.
	Reverse DC polarity	Have qualified service technician check and replace fuse, OBSERVE CORRECT POLARITY.
No output voltage, voltage indicator in upper red zone.	High input voltage	Make sure that inverter is connected to 12 V or 24 V battery. Check regulation of charging system.
Low battery alarm on all the time, voltage indicator below 11 V.	Poor DC wiring, poor battery condition.	Use proper cable and make solid connections. Use new battery.
No output voltage, Over Temp indicator on, load in excess of: 1500 W: 150 A or 75 A (24 V); 1000 W: 75 A or 37.5 A (24 V).	Thermal shutdown	Allow inverter to cool off. Reduce load if continuous operation required.
No output voltage, Over Temp indicator on, load less than: 1500 W: 150 A (12 V) or 75 A (24 V); 1000 W: 75 A (12 V) or 37.5 A (24 V).	Thermal shutdown	Improve ventilation, make sure ventilation openings in inverter are not obstructed, reduce ambient temperature.
No output voltage, Over Load indicator ON.	Short circuit or wiring error.	Check AC wiring for short circuit or improper polarity (hot and neutral reversed).
	Very high power load	Remove load

8. Maintenance

Very little maintenance is required to keep your inverter operating properly. You should clean the exterior of the unit periodically with a damp cloth to prevent accumulation of dust and dirt. At the same time, tighten the screws on the DC input terminals.



9.0 Disclaimer of Liability & Warranty

Go Power!TM provides the following limited 2 year warranty (“Warranty”) coverage as applicable to the purchaser (“Purchaser”) of the Go Power!TM branded product (“Product”) directly from Go Power!TM. The following constitutes the terms and conditions of that limited warranty.

9.1.1 What the Go Power! Warranty Covers and for How Long

Subject to the exclusions and claim procedure set out below, Go Power!TM warrants for a period of 2 years from the date of purchase at the point-of-sale to the original end-user customer (“Sale Date”), that the Go Power!TM Product provides coverage as follows:

For the period ending 2 years from the Sale Date, Go Power!TM will, at Go Power!TM's discretion, repair or replace the Product which fails to meet the Product Specifications due to a defect in materials or workmanship or apply credit towards the purchase of new Go Power!TM Product.

To exercise this right, the Purchaser shall ship, at its own expense, and return the Product to Go Power! according to the return instructions detailed below, and Go Power!TM will, repair or replace the Product and return it to the Purchaser free of charge, or offer credit towards the purchase of new Product.

Go Power!TM shall be entitled, at its discretion, to use new and/or reconditioned parts in performing warranty repair or providing a replacement Product. Go Power!TM also reserves the right to use parts or Product of original or improved design in any repair or replacement. All replaced Product and/or any parts removed from repaired Products become the property of Go Power!TM.

If Go Power!TM chooses to repair or replace a Product, the above warranty will continue to apply and remain in effect for the balance of the warranty period calculated from the Sale Date (and not the repair or replacement date).

If Go Power!TM chooses to offer a credit towards the purchase of new Product, then the warranty in effect and applicable to the new Product shall apply to the new Product.

9.1.2 What the Go Power! Warranty Does Not Cover

Go Power!TM's Warranty does not provide coverage for the following which are expressly excluded from the above warranty:

- Failure due to normal wear and tear of the Product.
- Failure caused by separate computer software supplied with or associated with a Go Power!TM Product.



-
- Failure due to fire, water, neglect, improper installation, generalized corrosion, biological infestations, or input voltages that create operating conditions beyond the maximum or minimum listed in the Go Power!TM specifications including lightning strikes.
 - Products which have been altered other than by Go Power!TM or authorized by Go Power!TM
 - Products that have their original identification (trademark, serial number) markings defaced altered or removed.
 - Products utilized as a component part of a product expressly warranted by another manufacturer.
 - Operation or storage of the Product outside the specification ranges, and/or alteration or deployment of Go Power!TM Products other than in accordance with any published or provided user, storage or maintenance requirements.
 - Failure that is in any way attributable to the improper use, storage, maintenance, installation or placement of the Go Power!TM Product.
 - Failure caused by abuse, misuse, abnormal use, or use in violation of any applicable standard, code or instructions for use in installations, including, but not limited to, those contained in the National Electrical Code, the Standards for Safety of Underwriters Laboratory, Inc., Standards for the International Electrotechnical Commission, Standards for the American National Standards Institute, or the Canadian Standards Association.
 - Failure due to acts of God.

9.1.3 Restrictions and Limitations to Go Power!'s Warranty

- This Warranty is not transferable and only applies to the Purchaser.
- Go Power!TM does not warrant the results obtained from the implementation of recommendations made by Go Power!TM or its authorized distributors concerning the use, design or application of Go Power! Products
- The end-user who purchases the Product assumes all responsibility and liability for loss or damage resulting from the handling or use of Go



Power!™ Products.

- Go Power!™'s liability on any claim, whether in warranty, contract, negligence, or any other legal theory, for loss, damage or injury arising directly or indirectly from or in relation to the use of the Go Power!™ Product shall in no event exceed the purchase price of the Go Power!™ Product which gave rise to the claim. IN NO EVENT SHALL GO POWER!™ BE LIABLE FOR PUNITIVE, SPECIAL, INCIDENTAL OR CONSEQUENTIAL DAMAGES WHETHER FORSEEABLE OR NOT INCLUDING BUT NOT LIMITED TO LOSS OF PROFITS OR REVENUES, LOSS OF USE OF GOODS, OR LOSS OF BARGAIN.
- The Warranty set out above is the sole warranty granted by Go Power!™ with respect to the Product. No oral understanding, representations or warranties shall be of any effect and Go Power!™ makes no further warranties, express or implied concerning the Go Power!™ Products other than the Warranty set out above. The Buyer, where permitted by applicable law, hereby expressly waives any statutory or implied warranty that the Go Power!™ Product shall be merchantable or fit for a particular purpose.

9.2 Warranty Return Procedure

Visit www.gpelectric.com to read the “frequently asked questions” section of our website to troubleshoot the problem. If trouble persists:

1. Call your Go Power!™ Technical Support team (1-866-247-6527).
2. Return defective product to place of purchase.

9.2.1 End Users

Contact your sales representative or Dealer and discuss the problem. Often the sales representative can troubleshoot common scenarios. If applicable, warranty will be handled between the End User and the Dealer. Go Power!™ will only accept returned items from an End User as a last resort. If you are unable to contact the Dealer, or the Dealer refuses to provide service, please contact Go Power!™ directly.

9.2.2 Dealers

Dealers will handle warranty either through their supplier or Go Power!™ if they qualify as a Purchaser.



9.2.3 Units bought directly from Go Power!

The Purchaser will return the product, freight prepaid, to Go Power!™ You must obtain a Return Material Authorization (RMA) number from Go Power!™ before returning a product. The RMA number MUST be clearly indicated on the outside of the box.

Items received without an RMA number will be refused.

9.2.3 Additional Information

Unless approved by Go Power!™ management, all product shipped collect to Go Power!™ will be refused.

Test items or items that are not under warranty, or units that are not defective, will be charged a minimum bench charge of (\$50.00 US) plus taxes and shipping.

A 15% restocking charge will be applied on goods returned and accepted as “new” stock.

9.4 Out of Warranty Items

Go Power!™ electronic products are non-repairable, Go Power!! does not perform repairs on its products nor does it contract out those repairs to a third party. Go Power!™ does not supply schematics or replacement parts for any of its electronic products.

10. Configuring your GPSW1500 and GPSW600

10.1 Configuring your GPSW1500

Switches are located on the rear left side.

Dip Switch (110 V)

S1	S2	V out (VAC)	S3	Freq. (Hz)	S4	n/a	S5	S6	Baud Rate
On	On	100	On	50	-	-	On	On	1200
Off	On	110	Off	60	-	-	Off	On	2400
On	Off	115	-	-	-	-	On	Off	4800
Off	Off	120	-	-	-	-	-	-	-

Dip Switch (220 V)

S1	S2	V out (VAC)	S3	Freq. (Hz)	S4	n/a	S5	S6	Baud Rate
On	On	200	On	50	-	-	On	On	1200
Off	On	220	Off	60	-	-	Off	On	2400
On	Off	230	-	-	-	-	On	Off	4800
Off	Off	240	-	-	-	-	-	-	-



10.2 Configuring the GPSW 600

Switches are located on the front panel.

Dip Switch (110 V)

	Freq. (Hz)
Up	50
Down	60



powered by  carmanah®

© 2011 GO POWER!™ By Carmanah Technologies
www.gpelectric.com

MOBI_MAN_GPSW-600-1500_vE_Dec2011